



KOMATSU WHEEL LOADER WA420-1



The machine shown may vary according to territory specifications.

KOMATSU: The Quality Is Standard

With excellent overall balance, this machine delivers the most efficient power and speed, enabling operators to accomplish more using less time and fuel.

Design points throughout improve durability and simplify maintenance to reduce overall operating costs.

Easy operating features reduce operator fatigue on any jobsite.

WA420-1

Flywheel horsepower: 172 kW 234 PS at 2200 RPM

Bucket capacities: 3,1 - 4,6_{m³} 4.0 - 6.0_{cu.yd}

Operating weight: 19600 kg 42,704 lb

KOMATSU



KOMATSU WHEEL LOADER WA420-1

IMPRESSIVE FEATURES

ENGINE

Reliable power: The engine is power-matched with Komatsu's heavy-duty construction equipment for unbeatable performance and durability.

Economical operation: The direct-injection system and special fuel-saving Cummins engine design provide excellent fuel economy.

Easy maintenance: All filters are spin-on type and concentrated on one side of the machine to facilitate operating checks and maintenance.

Low-noise operation: Ideal engineering, design and construction keep engine noise and vibration to a minimum.

TRANSMISSION

The full powershift, planetary-gear transmission with 4 forward and 4 reverse speeds is suitable for all jobsite conditions. The transmission control system includes a modulation valve to modulate the oil pressure used to operate the clutch. This eliminates shocks and reduces stress on the power train when shifting speeds or changing from direction, resulting in less operator fatigue and improved transmission durability. A neutral safety circuit allows starting only when the directional control lever is in neutral.

AXLES

Torque proportioning differentials minimise slippage, improve traction and increase the service life of the tires. The centre-pin-supported rear axle oscillates vertically and, along with an extra-long wheelbase and wide tread, assures machine stability over the roughest terrain.



BRAKES

Adjustment-free wet multiple-disc brakes ensure braking even on muddy or wet terrain. They are sealed to stay free of dirt and other abrasive contaminants.

Two brake pedals are provided for normal braking. In addition, when a switch is actuated the left pedal can be used to simultaneously brake and neutralize the transmission.

FRAME

High frame rigidity: The test loads applied in designing the loader linkage and frame were determined based on data obtained in the field. The result assures maximum durability even under the most severe load conditions. The rigid frames are highly resistant to both vertical and horizontal distortion.

BOOM & BUCKET

Z-bar loader linkages are made of high-tensile-strength steel for maximum rigidity and powerful excavation. Sealed loader linkage pins dust seals and cord rings extend greasing intervals. The bucket is made of high-tensile-strength steel. Bucket corner teeth minimize bucket wear and increase the penetration force.

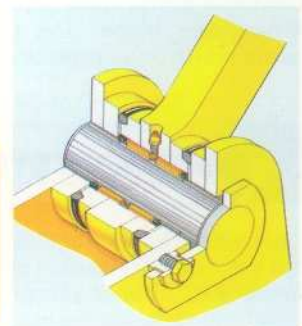
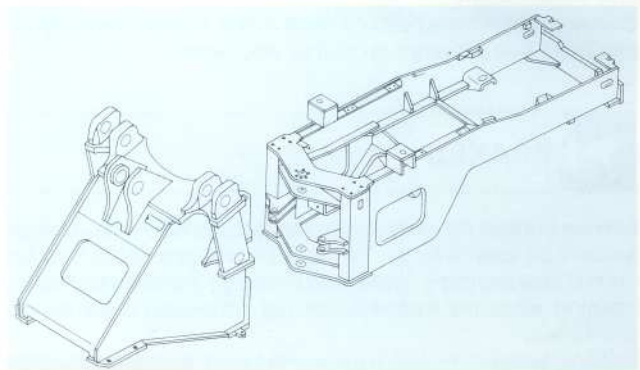



KOMATSU WHEEL LOADER WA420-1

GREATER PROFITS

HIGH PERFORMANCE FOR GREATER PRODUCTIVITY

Outstanding bucket and loader performance with faster, smoother traveling account for greater productivity. High dumping clearance, long dumping reach and excellent visibility make it easier to load dump trucks.



VALUE-ADDED FEATURES FOR MINIMAL MAINTENANCE

Electronic display and monitoring system EDIMOS: All important checkpoints are monitored and the operator is alerted through the sophisticated display panel in the event of a malfunction or emergency. The Electric System for Safety promotes foolproof operation.



Tilt-back engine hood: With generous footholds and access the mechanic can easily make engine checks, replace parts and perform other required maintenance.

CONTROLS FOR COMFORT AND EFFICIENCY



Operator's cab: Designed and laid out for maximum comfort and efficiency, the cab offers a wide field of vision, plenty of work space and ergonomically arranged instruments, levers and pedals. Vibration and noise are also kept to a minimum. The adjustable steering wheel tilts within a 100 mm (4") range for operating convenience. The suspension seat is fully adjustable for maximum operator comfort.



Fingertip control: The electrically controlled transmission requires just a light touch to shift, making gear changes as easy as flicking the turn signal lever.

Precise controls: Little effort is required to operate the bucket and boom control levers, assuring smooth, responsive bucket/boom action. In addition, the bucket positioner and the boom kickout device facilitate repeated digging/loading operations. The unique kick-down switch improves loading efficiency. Pressing this switch while the machine is moving in 2nd gear immediately shifts the transmission down to 1st gear. The full-hydraulic power steering uses a flow amplification system. The oil flow is controlled by a steering wheel-actuated metering pump. It facilitates precise approaches to machines and other obstacles.





KOMATSU WHEEL LOADER WA420-1



Model shown may include optional equipment.

MAIN FEATURES

- Electrically controlled transmission enables fingertip control of all machine functions
- Electronic system monitors machine operations and alerts the operator to any problem
- Tilttable steering wheel and adjustable suspension seat improve operator comfort and efficiency
- Torque proportioning differentials, 40° articulation, +/- 15° rear axle oscillation and long wheel base provide manoeuvrability and stability on any terrain
- Well laid-out work area maintains operator comfort and efficiency
- Wet disc brakes and sealed loader linkage pins provide higher performance with less maintenance
- Z-bar loader linkage ensures superior performance of working equipment

STANDARD EQUIPMENT

Standard and optional equipment may vary. Consult your Komatsu dealer for more information.

- Adjustable suspension seat
- Air over hydraulic brakes
- Alternator
- Automatic bucket positioner
- Battery
- Boom kickdown switch
- Boom kickout device
- Dust indicator
- Electrical transmission control
- Electric starting system
- Electronic display and monitoring system EDIMOS
- Emergency brake
- Engine key stop
- Fan guard
- Floor mat
- Four wheel drive system
- Front fenders
- Gauges fuel level, coolant temperature, torque convertor oil temperature, air pressure
- Heater and defroster
- Hitch
- Hydraulic power steering
- Ladders (left and right)
- Lighting system headlights, rear working lights, stop and tail lights, turn indicators (front and rear)
- Ordinary spare parts
- Powershift transmission 4 forward and 4 reverse
- Preheater
- Rear frame side cover
- Rops brackets
- Rops canopy
- Seat belt
- Sight gauges hydraulic reservoir level, brake oil level
- Speedometer
- Steel cab with rear view mirror, window washer and wiper (front and rear), sun visor
- Tilttable steering wheel
- Tire inflation kit
- Toolkit
- Torque proportioning differentials
- Turbo charged aftercooled engine
- Vandalism protection kit
- Wet type disc brakes

EDIMOS monitoring system:

PILOT LAMPS: Engine preheating, high beam, working lights, turn indicators, parking brake applied, transmission cut-off

MONITOR LIGHTS: Engine oil level, brake oil level, coolant level

CAUTION LAMPS: Battery charging, fuel level, oil filters clogging (engine, transmission), transmission oil filter clogging

CAUTION LAMPS WITH ALARM: Engine oil pressure, coolant level, coolant temperature, torque convertor oil temperature, air pressure, parking and neutral, brake line failure

OPTIONAL EQUIPMENT

Additional counterweight
Air conditioner
Bucket attachment
Car radio

Emergency steering
Fire extinguisher
Hydraulic adaptor kit
Kits for special operating conditions

License plate light
Power train guard
Reversing alarm
Reversing light

Rops canopy
3 spool valve
TBG specs
Wide variety of buckets
Variety of tyres and rims

KOMATSU

KOMATSU EUROPE N.V.

Mechelsesteenweg 586, B 1800 VILVOORDE (BELGIUM)
Tel. (+32) 2/254 04 11 Fax (+32) 2/252 19 81
Telex: 24.380 Eukomb Cable: KOMASEI, Bru B

SPECIFICATIONS OF WA420-1



ENGINE

The CUMMINS 6 CTA 8,3 is a 4-stroke, water-cooled, overhead valve, direct-injection turbocharged aftercooled diesel engine with six cylinders, a 114 mm (4.5") bore x 135 mm (5.3") stroke and 8,3 l (506 cu.in) piston displacement.

Flywheel horsepower:

167 kW (227 PS) at 2200 RPM (DIN 70020)

172 kW (234 PS) at 2200 RPM (DIN 6270 B)

167 kW (224 HP) at 2200 RPM (SAE J1349)

Direct-injection fuel system. All-speed mechanical governor.

Gear-pump-driven force-lubrication with full-flow filters.

All filters are spin-on type for easy maintenance. Dry, cyclo-pack air cleaner with dust evacuation valve for longer element service. 7,5 kW/24 V electric starting motor. 24 V/55 A alternator. 2 x 12 V/143 Ah batteries.



TRANSMISSION

3-element, single-stage, single-phase torque converter. Full powershift, planetary-gear type transmission. A modulating function assures smooth speed and directional changes without braking. An electrically controlled transmission allows fingertip control of speed and directional change levers. A neutral safety circuit allows starting only when the directional control lever is in neutral.

| Travel speed km/h (MPH) | Forward | Reverse |
|----------------------------|-----------------|-----------------|
| 1st | 0 - 6,7 (4.2) | 0 - 7,6 (4.7) |
| 2nd | 0 - 12,0 (7.5) | 0 - 13,4 (8.3) |
| 3rd | 0 - 20,3 (12.6) | 0 - 22,4 (13.9) |
| 4th | 0 - 34,1 (21.2) | 0 - 37,4 (23.2) |



AXLES & FINAL DRIVES

Four-wheel drive system. A full-floating front axle is fixed to the front frame; centre-pin-supported, full-floating rear axle with wide oscillation of $\pm 15^\circ$, spiral bevel gear for reduction and a planetary gear for final reduction. The front and rear torque proportioning differentials of the straight bevel gear minimise tyre slippage on soft or wet terrain.



BRAKES

Service brakes: Air-over-hydraulic, wet, multiple-disc, brakes actuate all four-wheels. Two pedals are provided, one for normal braking (right-hand) and braking + transmission neutralising when the transmission cut-off switch is turned on (left-hand).

Parking brake: Dry disc type, air released, spring applied on front axle pinion shaft.

Emergency brake: The parking brake is automatically actuated when air pressure goes below the rated value.



STEERING SYSTEM

Centre pivot frame articulation. Fully-hydraulic power assisted steering independent of engine RPMs. Wide articulation angle of 40° on each side provide minimum turning radius of 6600 mm (21'8") at the outside corner of the bucket.



TYRES

Front and rear: 23.5-25-16PR (L-2)

Rims: 19.5 x 25 WTB



BOOM & BUCKET

Z-bar loader linkage is made from high-tensile-strength steel for maximum rigidity and powerful excavation. Rap-out loader linkage design for shock dumping of sticky materials. Sealed loader linkage pins with dust seals extend greasing intervals. The bucket is made from high tensile steel; bucket corner teeth (optional) not only minimise bucket wear but also increase penetrating force.



BUCKET CONTROLS

Easy to operate, the bucket and boom control levers, assures smooth, responsive action. In addition, the bucket positioner and the boom kickout device facilitate repeated digging and loading operations.

Control positions:

Boom Raise, hold, lower and float

Bucket Tilt-back, hold and dump



HYDRAULIC SYSTEM

2 gear pumps for steering and loader control.

Capacity (discharge flow) at engine 2200 RPM

Loader pump 170 + 106 l/min

Steering pump 134 l/min

Relief valve setting:

Loader 20,6 MPa (210 kg/cm²/3000 PSI)

Steering 19,6 MPa (210 kg/cm²/3000 PSI)

Control valve: 2-spool type.

| Hydraulic cylinders | Number of cylinders | Bore | Stroke |
|---------------------|---------------------|----------------|----------------|
| Boom | 2 | 160 mm (6.30") | 769 mm (30'3") |
| Bucket | 1 | 200 mm (7.9") | 485 mm (19'1") |
| Steering | 2 | 90 mm (3.5") | 442 mm (17.4") |

Hydraulic cycle time (rated load in bucket):

Raise.... 6,7 s/Dump.... 1,5 s/Lower (empty).... 3,6 s



ROPS/FOPS AND CAB

Dimensions comply with ISO 3471 and SAE J1040c ROPS (Roll-Over Protective Structure) standards, as well as ISO 3449 FOPS (Falling Object Protective Structure) standards.



SERVICE REFILL CAPACITIES

Cooling system 52,0 l

Fuel tank 293,0 l

Engine 22,0 l

Brake oil tank 7,0 l

Hydraulic system 103,0 l

Axle (each front and rear) 55,0 l

Torque converter and transmission 47,0 l



DIMENSIONS

Unit: mm (ft.in)

Dimensions vary according to tyre size

| Tyre size | 23.5-25 | 26.5-25 |
|------------------------------|----------------|----------------|
| Tread | 2200 mm (7'3") | 2200 mm (7'3") |
| Width over tyres | 2800 mm (9'2") | 2890 mm (9'6") |
| Change in vertical dimension | 0 | +75 mm (2.95") |
| Change in reach | 0 | -70 mm (2.76") |
| Change in digging depth | | |
| 0° | 0 | -75 mm (2.95") |
| 10° | 0 | -75 mm (2.25") |
| Change in overall length | | |
| Bucket on ground | 0 | -65 mm (2.56") |
| Bucket at carry | 0 | -35 mm (1.38") |

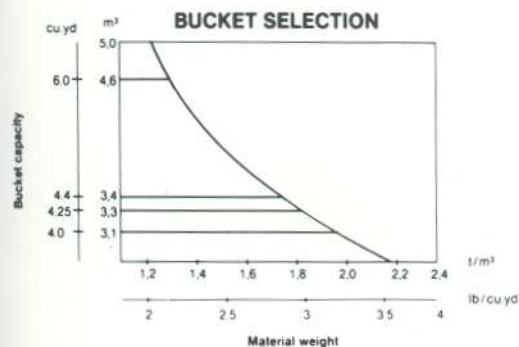
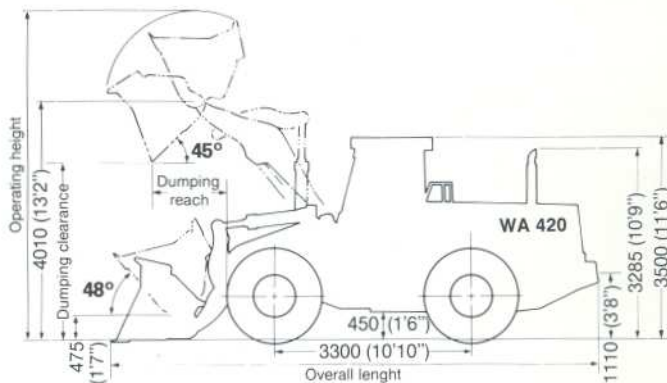

- 3,4 m³ (4.4 cu.yd) Loose material bucket with tip-type teeth.** (Loading and excavation of soil, sand and a variety of other commonly handled materials).
- 3,3 m³ (4.25 cu.yd) Excavating bucket with bolt-on cutting edge.**
- 3,1 m³ (4.0 cu.yd) Excavating bucket with bolt-on teeth** (Loading and excavation of crushed rock and blasted rock).
- 4,6 m³ (6.0 cu.yd) Light material bucket with bolt-on cutting edge** (A lighter-weight, large capacity bucket).
- 3,1 m³ (4.0 cu.yd) Rock bucket (Spade nose)** (Loading and excavation of blasted rock).

| Bucket type | Loose material | |
|---|------------------|----------------------|
| | Tip type teeth | |
| Bucket capacity | SAE rated | 3,4 m³ (4,4 cu.yd) |
| Bucket width | | 3050 mm (10') |
| Bucket weight | | 2000 kg (4,409 lb) |
| Static tipping load | Straight | 14880 kg (32,805 lb) |
| | Full turn | 12965 kg (28,583 lb) |
| Dumping clearance, max. height and 45° dump angle | | 2990 mm (9'10") |
| Reach at 2130 mm (7') cut edge clearance and 45° dump angle | | 1545 mm (5'8") |
| Reach at max. height and 45° dump angle | | 1065 mm (3'6") |
| Reach with arm horizontal and bucket level | | 2400 mm (7'10") |
| Operating height (fully raised) | | 5510 mm (18'1") |
| Overall length | Bucket on ground | 7810 mm (25'7") |
| | Bucket at carry | 7765 mm (25'6") |
| Turning radius (bucket at carry, outside corner of bucket) | | 6565 mm (21'6") |
| Digging depth | 0° | 75 mm (2'10") |
| | 10° | 285 mm (1'12") |
| Breakout force (bucket cylinder) | | 19870 kg (43,805 lb) |
| Operating weight | | 19600 kg (43,210 lb) |

- All dimensions, weights and performance values based on SAE J-732C and J742b standards.
- For increases or decreases according to tyre size, refer to the table in DIMENSIONS.
- Static tipping load and operating weight shown include 23.5-25-16PR (L-3) tubeless tyres with 1050 kg (2,315 lb) ballast in rear, lubricants, coolant, full fuel tank, steel cab, ROPS Canopy and operator. Machine stability and operating weight are affected by counterweight, tyre size and other attachments. Use either tyre ballast or counterweight, not both. Add the following weight changes to operating weight and static tipping load.

| Tyres and options | Change in operating weight | Change in tipping load | |
|---|----------------------------|------------------------|---------------------|
| | | Straight | Full turn |
| 23.5-25-16PR (L-3) tubeless tyres without ballast | -1050 kg (2,315 lb) | -1625 kg (3,605 lb) | -1440 kg (3,175 lb) |
| 26.5-25-20PR (L-3) tubeless tyres with ballast | +1175 kg (2,590 lb) | +1170 kg (2,580 lb) | +1030 kg (2,271 lb) |
| 26.5-25-20PR (L-2) tubeless tyres without ballast | -205 kg (452 lb) | -657 kg (1,448 lb) | -860 kg (1,896 lb) |
| Remove ROPS canopy | -475 kg (1,047 lb) | -520 kg (1,146 lb) | -485 kg (1,069 lb) |
| Remove Steel cab | -285 kg (628 lb) | -255 kg (562 lb) | -245 kg (540 lb) |
| Additional counterweight in place of ballast | -750 kg (1,654 lb) | -875 kg (1,929 lb) | -840 kg (1,852 lb) |