

INDUSTRIAL DIESEL ENGINE

Kubota V3 Series (4-Cylinder)

V3800DI-T-E3B



Rated Power

74.0 kW @ 2600 rpm



Photograph may show non-standard equipment.

Performance Curves

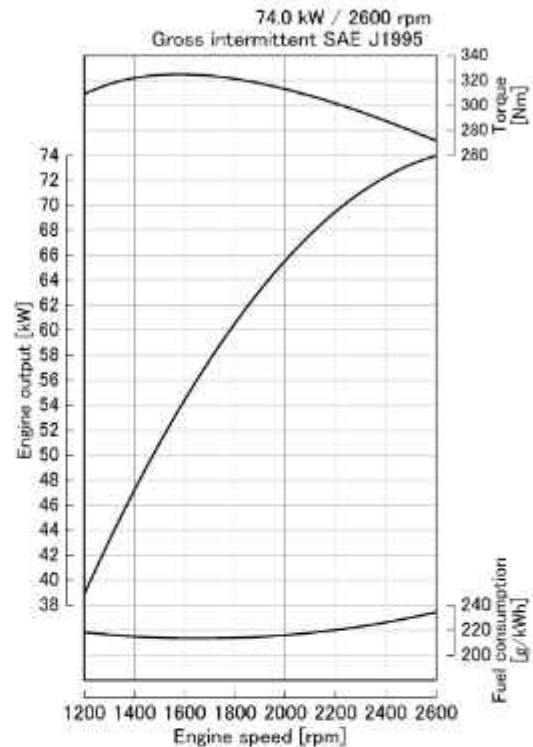

Features and Benefits

Emissions

The Kubota V3800 direct injection turbocharged engine complies with the EPA / CARB Tier 3 + EU Stage IIIA emissions. These engines meet emissions regulations with minimal additional required devices. For example, NOx is reduced by mechanical means alone, including the use of a cooled exhaust gas recirculation (EGR) system.

Durable Power

Within Kubota's industrial diesel engine lineup, the V3800DI-T engine has high output of the 75 kW range and below among Kubota's engine line-up. This engine requires no electronic control devices in order to comply with the stringent emission regulations.

Clean and Quiet Power

Kubota's original E-CDIS (Center Direct Injection System) combustion system, renowned for clean combustion, has been updated. Fuel injection pressure has been increased. The half-float valve cover and MoS₂-coated pistons reduce noise levels and decrease vibrations transmitted from the valve area, providing enhanced noise reduction.

For Earth, For Life
Kubota

V3800DI-T-E3B

Engine Specifications

Engine model	V3800DI-T-E3B	
Emission regulation	EPA/CARB Tier 3 level + EU Stage IIIA level	
Type	Vertical, water cooled 4-cycle diesel engine	
Cylinders	4	
Bore and stroke	mm (in)	100.0 x 120.0 (3.937 x 4.724)
Displacement	L (cu.in)	3.769 (230.0)
Aspiration	Turbocharged	
Aftertreatment	-	
Rated output / speed ^{†1}	kW (HP) / rpm	74.0 (99.2) / 2600
Maximum torque / speed ^{†1}	Nm (lb-ft) / rpm	325.0 (239.7) / 1600
Combustion system	Direct injection	
Fuel system	In-line pump	
Length x Width x Height ^{†2} (without aftertreatment unit)	mm (in)	699 x 544 x 793 (27.5 x 21.4 x 31.2)
Length x Width x Height ^{†3} (with aftertreatment unit)	mm (in)	-
Dry weight ^{†3}	kg (lbs)	275 (606)

Specifications are subject to change without notice.
Dimensions and dry weight are according to Kubota's standard specification.
Dimensions and weight depend on completed specifications.

^{†1}: SAE J1995 gross intermittent

^{†2}: Exclude cooling fan and exclude aftertreatment unit.

^{†3}: Exclude cooling fan and include aftertreatment unit on engine.

Dimensions

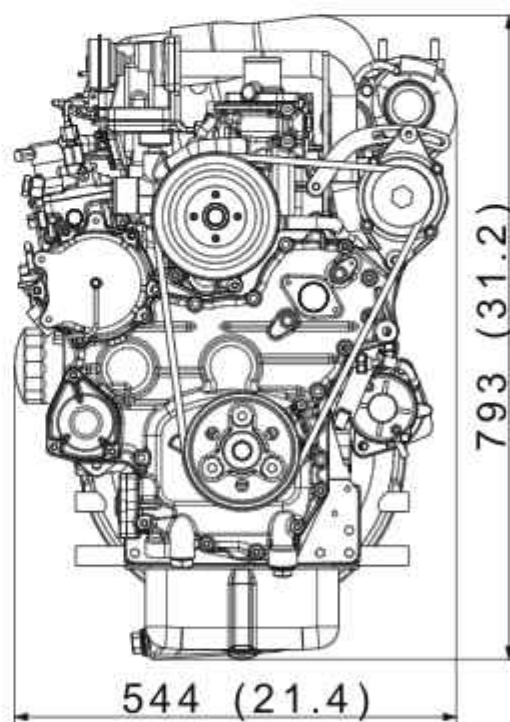
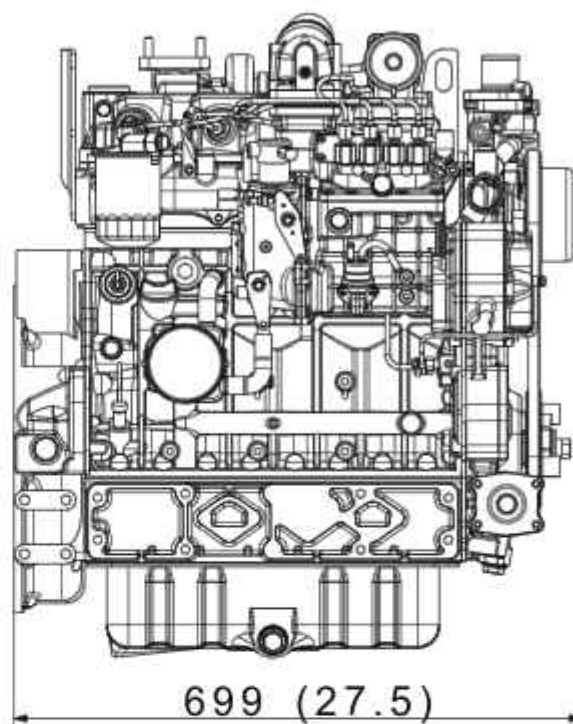

Kubota Corporation

2-47, Shikitsuhigashi 1-chome Naniwa-ku, Osaka, 556-8601 Japan

<https://global.engine.kubota.co.jp/en/>

ASP-V3800DI-T-E3B1808-R1-I